

[BMW F11 530d xDrive Touring / Repair Manuals and Technical Data / 37 Integrated Suspension Systems / 37 12 Control and suspension elements, rear /](#)

37 12 310 Removing and installing/replacing rear left or right shock absorber



Note:

- Read and comply with [notes on replacing shock absorbers](#).
- Read and comply with BMW Parts Department notes.

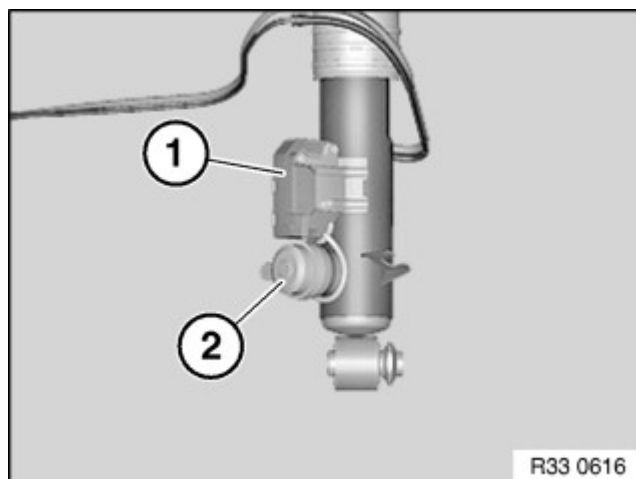

Important!

Handle the spring strut with care so as to avoid damaging the control unit (1) and control valve (2).



Necessary preliminary work:

- Remove [rear wheel](#)
- Deactivate and drain [air spring system](#)

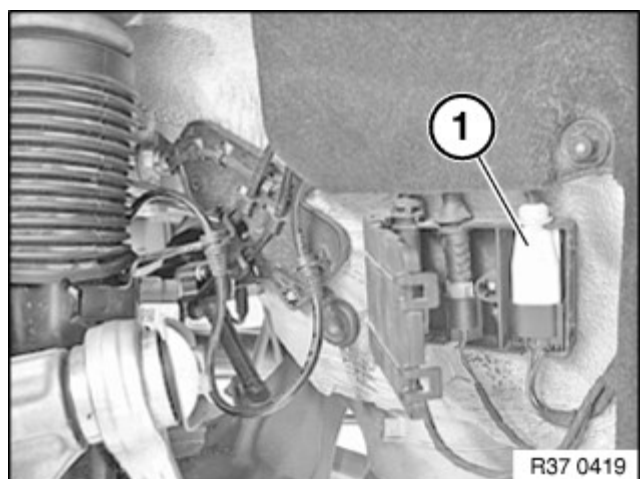

If applicable, disconnect the plug connections (1) and expose lines up to shock absorber.

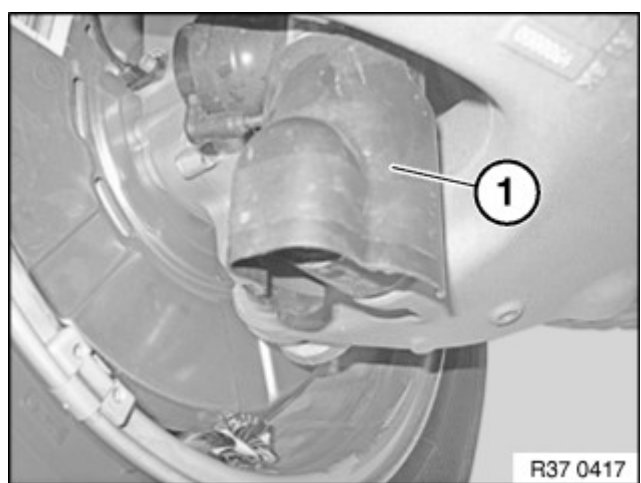

Remove cover (1).

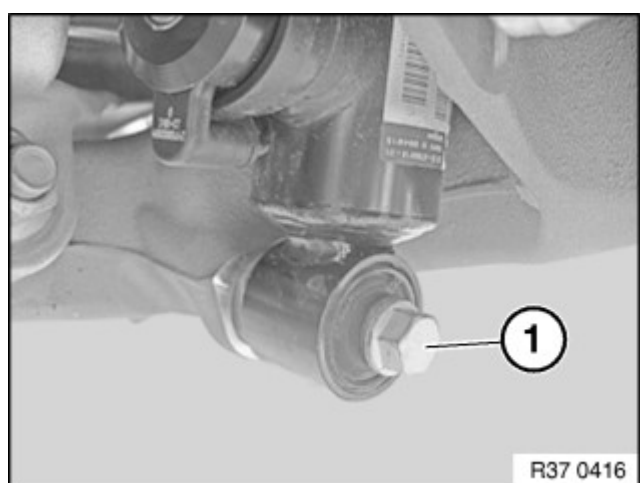

Release screw (1). *Installation note:* Before tightening screw/bolt connection, check that shock absorber pin is correctly positioned in swinging arm. Screw must not be used as a fitting aid to installing the shock absorber!

Replace bolt!

Tighten bolt in [normal position](#).

Tightening torque, [33 52 4AZ](#).

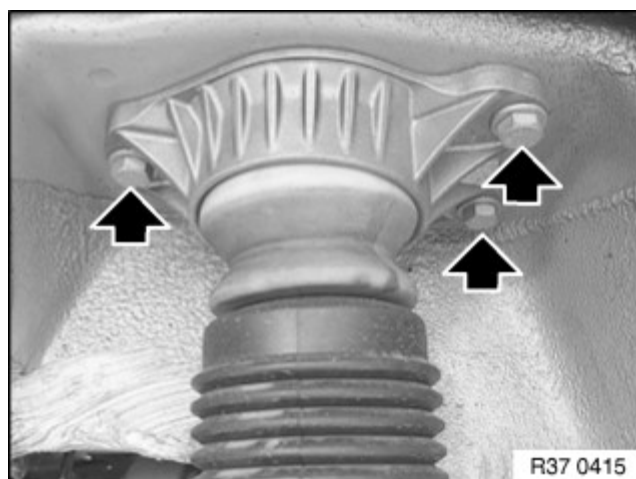

Release screws at support bearing.

Replace self-locking screws!

Tightening torque, [33 52 1AZ](#).

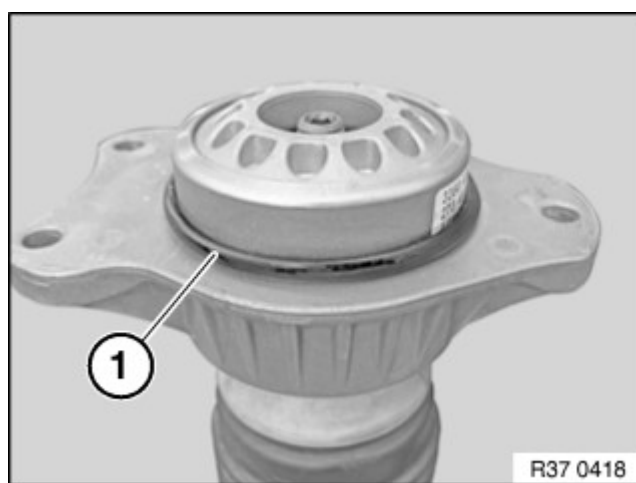

Installation note:

Check O-ring and replace if necessary.

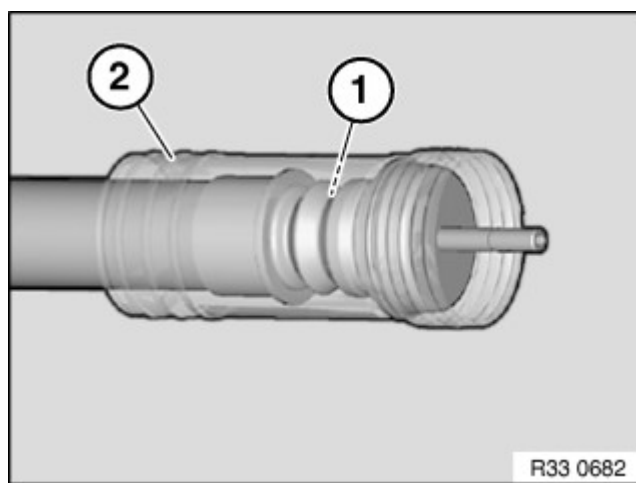

Replacement:

Modify [support bearing](#).

Modify auxiliary absorber (1) and protective tube (2) incl. support cup.

Installation note:

Check auxiliary absorber (1) and protective tube (2) for damage, replace if necessary.

**After Installation note:**

- Activate and fill [air spring system](#)
- Replacement only: Program/encode the shock absorber and check the software version
- If applicable, perform the [vertical acceleration sensor adjustment](#) in the event of a replacement only

For informational purposes only. The information on this website is provided AS-IS with no warranties, express or implied, and is not guaranteed to be error-free, up-to-date or complete. NewTIS and BMW assume no liability for any loss or damage arising from the use or reliance on the information and content on this website. The content on this website is subject to change without notice.